

VARIMETER

Undervoltage Relay To Detect Auto-Reclosing IL 9079, SL 9079

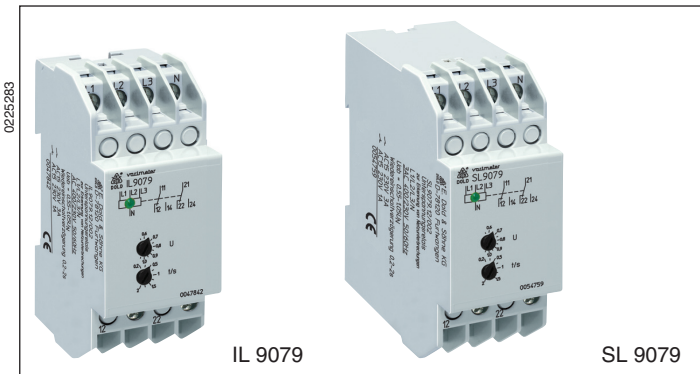

- According to IEC/EN 60 255-1
- Fast detection of undervoltage or phase failure in three-phase voltage systems
- Detects auto reclosing of 20 ms
- Adjustable response value $0.55 \dots 1.05 U_N$
- Operate delay to generate a defined reset signal
- Manual reset possible with external circuit
- Single-phase connection possible
- Optionally fixed response value $0.8 U_N$
- De-energized on trip
- Green LED indicate for closed contact
- Independent of phase sequence
- 3p4w connection
- Optionally for 3p3w systems
- 2 changeover contacts
- Devices available in 2 enclosure versions:
 - IL 9079: depth 59 mm, with terminals at the bottom for installation systems and industrial distribution systems according to DIN 43 880
 - SL 9079: depth 98 mm, with terminals at the top for cabinets for mounting plate and cable duct
- Width 35 mm

Function Diagram

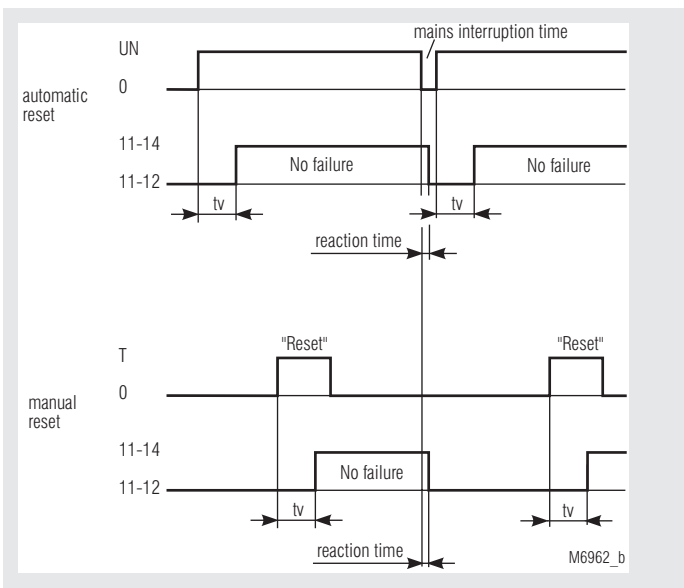

Approvals and Markings



*) nur IL 9079

Applications

Monitoring of voltage systems to detect auto reclosing as e.g. generated by the energy supplier in the case of flash-overs or switching procedures. It is possible that in control circuits some of the devices are reset during auto reclosing and some not. Because of this uncontrollable situations may occur.

By detecting these fast auto reclosings and addition of a certain time delay at reclosing the OFF-time is lengthened and every device has the time to reset. The circuit goes into a defined OFF state and is automatically reset after the adjusted time delay or by manual reset if the automatic reset is disabled by an external circuit (see connection examples).

Circuit Diagram

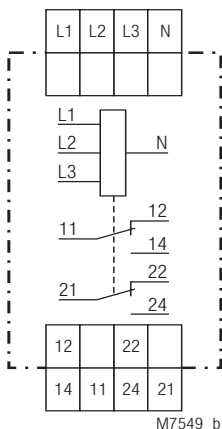

IL 9079.12, SL 9079.12

Function

The voltage of each phase is measured against N (with devices without N L1 and L2 are measured against L3). If at least 1 phase voltage goes under the response value (e.g. $0.8 U_N$) the green LED goes off and the output relay deenergizes (fault condition). Only when all 3 phases go over the reset value (e.g. $0.85 U_N$) again the output relay energizes after the adjustable operate delay t_v and the green LED comes on.

Indicators

green LED: on, when the mains system is working properly
(contact 11-14 and 21-24 closed)

Notes

For single phase operation the terminals L1, L2 and L3 have to be bridged.

Technical Data

Input

Nominal voltage U_N :

IL/SL 9079.12 and 002:	3/N AC 400 / 230 V
IL/SL 9079.12/001 and /003:	3 AC 400 V, 3 AC 500 V
SL 9079/103:	3 AC 400 V, 3 AC 500 V

Maximum overload: 1.1 U_N , permanent

Nominal consumption: approx. 8 VA

Nominal frequency: 50 / 60 Hz

Input resistance: approx. 150 k Ω

Setting Ranges

Response / Reset value

IL/SL 9079.12 and /001:	0.8 U_N / 0.85 U_N
IL/SL 9079/002 und /003:	adjustable 0.55 ... 1.05 U_N
SL 9079/103 3 AC 400 V:	adjustable 0.8 ... 1.05 U_N
SL 9079/103 3 AC 500 V:	adjustable 0.7 ... 1.05 U_N

hysteresis 4 %

Detection of auto-reclosing: ≥ 20 ms at response value 0.8 U_N

≥ 35 ms at response value 0.6 U_N

Reaction time on phase failure:

approx. 40 ms at response value 0.8 U_N

approx. 55 ms at response value 0.6 U_N

Reclosing delay:

adjustable, 0.2 ... 2 s

Output

Contacts:

IL 9079.12, SL 9079.12: 2 changeover contacts

Contact material: AgNi

Switching voltage: AC 250 V

Thermal current I_{th} : 4 A

Switching capacity
to AC 15

NO contact: 3 A / AC 230 V IEC/EN 60 947-5-1

NC contact: 1 A / AC 230 V IEC/EN 60 947-5-1

Electrical life IEC/EN 60 947-5-1

to AC 15 at 1 A, AC 230 V: 5 x 10⁵ switching cycles

Short circuit strength

max. fuse rating: 4 A gL IEC/EN 60 947-5-1

Mechanical life: 30 x 10⁶ switching cycles

General Data

Operating mode: Continuous operation

Temperature range:

Operation: - 20 ... + 60 °C

Storage: - 25 ... + 60 °C

Relative air humidity: 93 % at 40 °C

Altitude: < 2,000 m

Clearance and creepage distances

rated rated impulse voltage voltage /
pollution degree: 4 kV / 2 IEC 60 664-1

EEMC

Electrostatic discharge: 8 kV (air) IEC/EN 61 000-4-2

HF irradiation

80 MHz ... 1 GHz: 10 V / m IEC/EN 61 000-4-3

1 GHz ... 2 GHz: 10 V / m IEC/EN 61 000-4-3

2 GHz ... 2.7 GHz: 10 V / m IEC/EN 61 000-4-3

Fast transients: 4 kV IEC/EN 61 000-4-4

Surge voltages

between

wires for power supply: 2 kV IEC/EN 61 000-4-5

between wire and ground: 2 kV IEC/EN 61 000-4-5

Interference suppression: Limit value class B EN 55 011

Degree of protection

Housing: IP 40 IEC/EN 60 529

Terminals: IP 20 IEC/EN 60 529

Housing: Thermoplastic with V0 behaviour
according to UL subject 94

Vibration resistance: Amplitude 0.35 mm,

frequency 10 ... 55 Hz, IEC/EN 60 068-2-6

Climate resistance: 20 / 060 / 04 IEC/EN 60 068-1

Terminal designation: EN 50 005

Technical Data

Wire connection:

2 x 2.5 mm² solid or
2 x 1.5 mm² stranded ferruled
DIN 46 228-1/-2/-3/-4

Wire fixing:

Flat terminals with self-lifting
clamping piece IEC/EN 60 999-1

Fixing torque:

0.8 Nm

Mounting:

DIN rail IEC/EN 60 715

Weight

IL 9079: 110 g

SL 9079: 137 g

Dimensions

Width x height x depth

IL 9079: 35 x 90 x 59 mm

SL 9079: 35 x 90 x 98 mm

Standard Types

IL 9079.12/002 3/N AC 400 / 230 V 0.55 ... 1.05 U_N 0.2 ... 2 s

Article number: 0047842

SL 9079.12/002 3/N AC 400 / 230 V 0.55 ... 1.05 U_N 0.2 ... 2 s

Article number: 0054759

- 3p4w connection
- Output: 2 changeover contacts
- Nominal voltage U_N : 3/N AC 400 / 230 V
- Adjustable response value: 0.55 ... 1.05 U_N
- Adjustable reclosing delay: 0.2 ... 2 s
- Width: 35 mm

Variants

IL 9079: for 3p4w systems, fixed response value 0.8 U_N

IL 9079/001: for 3p3w systems, fixed response value 0.8 U_N

IL 9079/002: for 3p4w systems,
adjustable response value 0.55 ... 1.05 U_N

IL 9079/003: for 3p3w systems,
adjustable response value 0.55 ... 1.05 U_N

IL 9079/103: for 3p3w systems,
adjustable response value 0.8 ... 1.05 U_N
adjustable response value 0.7 ... 1.05 U_N
with transformer for mains with harmonic content

Ordering example for variants

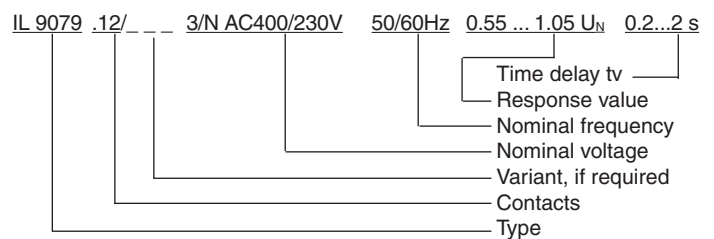

Connection Examples

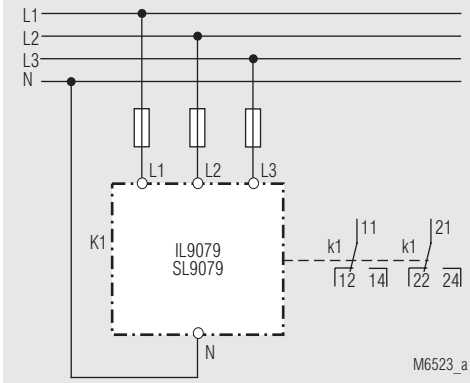

IL/SL 9079 and IL/SL 9079/002

Connection Examples

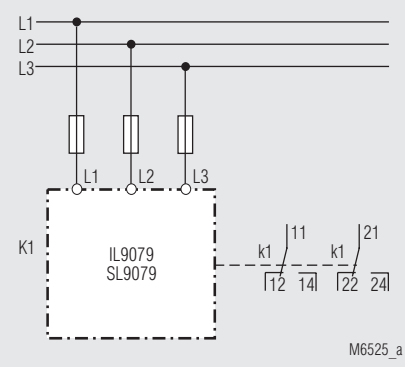

IL/SL 9079/001 and /003; SL 9079/103

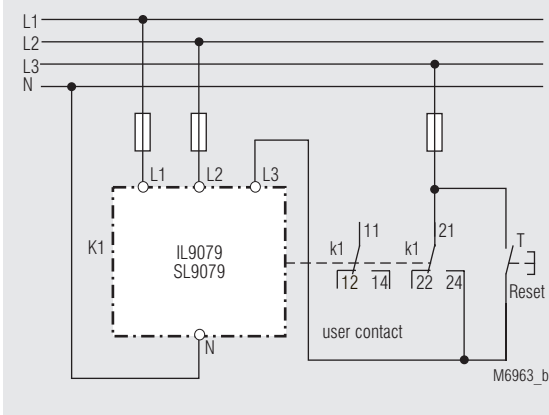

IL/SL 9079 and IL/SL 9079/002

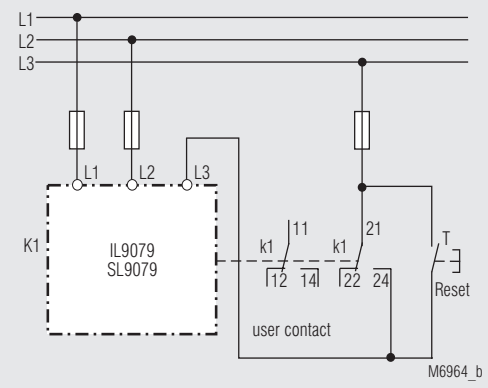

IL/SL 9079/001 and /003; SL 9079/103

