

VARIMETER

Phase Sequence Module

IL 9059, SL 9059, OA 9059

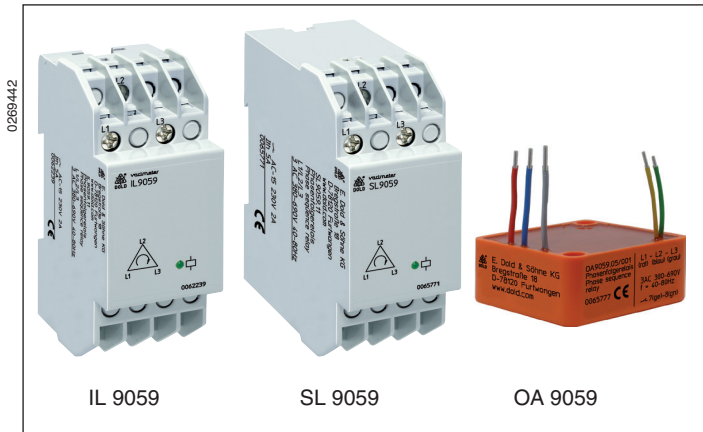

Your Advantages

- Protects mobile equipment against damage or destruction coming from wrong phase sequence
- OA 9059: reduced wiring by mounting directly in the motor connection box

Features

- According to IEC/EN 60255-1
- Detection of incorrect phase sequence
- No separately auxiliary voltage necessary
- Nominal voltage range 3 AC 380 ... 690 V
- Suitable for operation with inverters (f = 40 ... 80 Hz)
- Relay output:
 - IL/SL 9059: 1 changeover contact
 - OA 9059: 1 NC contact
- Extended temperature range
- Devices available in 3 enclosure versions:
 - IL 9059: depth 59 mm, with terminals at the bottom for installation systems and industrial distribution systems according to DIN 43 880
 - SL 9059: depth 98 mm, with terminals at the top for cabinets with mounting plate and cable duct
 - OA 9059: sealed modul with stranded wire connection suitable for mounting in terminal box
- Width
 - IL/SL 9059: 35 mm
 - OA 9059: 62 mm

Function Diagrams

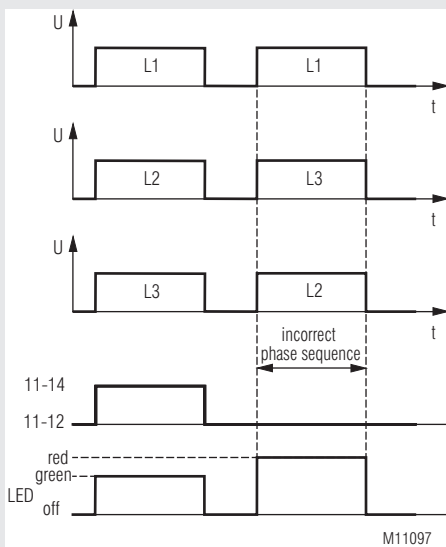

IL 9059, SL 9059

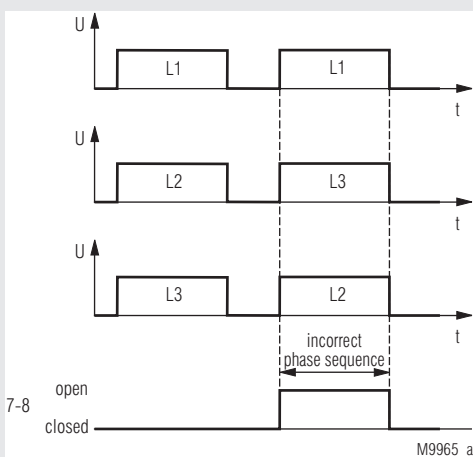

OA 9059/001

Approvals and Markings



*) only IL 9059

Applications

In many application with pumps, conveyors and fans efficient monitoring systems should help to detect failures and misfunctions in time, to avoid damage and long times of non-operation.

Besides speed and frequency the monitoring of phase sequence is very important.

The phase sequence relay with it's wide voltage range of 3AC380-690V detects a wrong phase sequence and signals via a galvanically separated relay contact the wrong rotation of a motor.

By integrating the relay output into the enabling circuit of a plant, the unit disables the start of the plant in the case of wrong phase sequence. especially portable equipment can be protected in this way.

Indicators

2-colour LED at IL/SL 9059

green: correct phase sequence contacts 11-14 closed

red: incorrect phase sequence contacts 11-12 closed

Circuit Diagrams

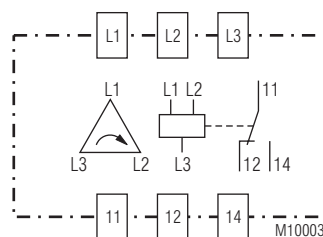

IL 9059, SL 9059

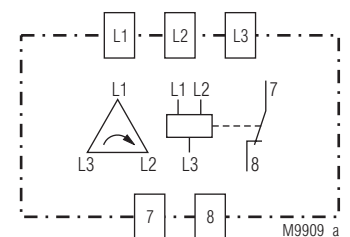

OA 9059

Connection Terminals	
Terminal designation	Signal designation
L1, L2, L3	Input circuit OA 9059: L1 (red), L2 (blue), L3 (grey)
7, 8 (OA 9059)	NO contact: 7 (yellow), 8 (green)
11,12,14 (IL/SL 9059)	Changeover contact

Technical Data

Input circuit

Nominal voltage U_N:	3 AC 380 ... 690 V
Voltage range:	0.85 ... 1.1 U_N (3 AC 320 ... 760 V)
Nominal frequency:	ca. 3 VA
Frequency range:	40 ... 80 Hz (main frequency); suitable for operation with inverters with independant pulse frequency

Output

Contact	
IL/SL 9059:	1 changeover contacts
OA 9059:	1 NC contact
Contact material:	AgNi 0.15 gold plated
Switching voltage:	AC 250 V
Response time:	After connection of all 3 phase with incorrect phase sequence until NC contact at OA 9059/001 opens: approx. 100 ms

Thermal current I_{th} :

IL/SL 9059:	5 A
OA 9059:	2 A

Switching capacity IL/SL 9059

to AC 15:	2 A / AC 230 V	IEC/EN 60 947-5-1
to DC 13:	2 A / DC 24 V	IEC/EN 60 947-5-1

Switching capacity OA 9059

to AC 15:	1 A / AC 230 V	IEC/EN 60 947-5-1
to DC 13:	1 A / DC 24 V	IEC/EN 60 947-5-1

Electrical life:

1.5 x 10⁵ switching cycles

Short circuit strength

max. fuse rating:

IL/SL 9059:	4 A gL	IEC/EN 60 947-5-1
OA 9059:	2 A gL	IEC/EN 60 947-5-1

Mechanical life:

≥ 30 x 10⁸ switching cycles

General Data

Operating mode: Continuous operation

Temperature range

Operation	
IL/SL 9059:	- 30 ... + 70°C
OA 9059:	- 30 ... + 75°C
Storage	
IL/SL 9059:	- 40 ... + 70°C
OA 9059:	- 45 ... + 75°C
Relative air humidity:	93 % at 40 °C
Altitude:	< 2,000 m

Clearance and creepage distances

rated rated impulse voltage voltage /

pollution degree;

Output to Input:	6 kV / 3	IEC 60 664-1
------------------	----------	--------------

EMC

Statische Entladung (ESD):	8 kV (Luftentladung)	IEC/EN 61 000-4-2
HF irradiation		
80 MHz ... 1 GHz:	10 V / m	IEC/EN 61 000-4-3
IL/SL 9059:		
1 GHz ... 2 GHz:	3 V / m	IEC/EN 61 000-4-3
2 GHz ... 2.7 GHz:	3 V / m	IEC/EN 61 000-4-3
OA 9059:		
1 GHz ... 2 GHz:	10 V / m	IEC/EN 61 000-4-3
2 GHz ... 2.7 GHz:	10 V / m	IEC/EN 61 000-4-3
Fast transients:	2 kV	IEC/EN 61 000-4-4
HF-wire guided		
IL/SL 9059:	30 V / m	IEC/EN 61 000-4-6
OA 9059:	10 V / m	IEC/EN 61 000-4-6
Surge voltages:	2 kV	IEC/EN 61 000-4-5
Interference suppression:	Limit value class B	EN 55 011

Technical Data

Degree of protection:

IL/SL 9059: Housing: IP 40 EN 60 529

Terminals: IP 20 EN 60 529

OA 9059: Module is completed sealed-in

Housing:

IL/SL 9059: Thermoplastic with V0 behaviour
according to UL subject 94

OA 9059: Potting compound UL approval

Vibration resistance: Amplitude 0.35 mm,
frequency 10 ... 55 Hz, IEC/EN 60 068-2-6

Climate resistance:

IL/SL 9059: 30 / 070 / 04 IEC/EN 60 068-1

OA 9059: 30 / 075 / 04 IEC/EN 60 068-1

Wire connection:

IL/SL 9059: 2 x 2.5 mm² solid DIN 46 228
2 x 1.5 mm² stranded ferruled
DIN 46 228-1 /-2 /-3

OA 9059:

L1; L2; L3: 0.5 mm², double insulation

7; 8: 0.25 mm², double insulation

wire length: 25 cm

Wire fixing IL/SL 9059: Flat terminals with self-lifting clamping
piece EN 60 999

Fixing torque:

IL/SL 9059: 0.8 Nm

Mounting

IL/SL 9059: DIN rail IEC/EN 60 715

OA 9059

Mounting screws: M4 x 25 mm

Fixing torque: 1.2 Nm

Weight:

IL 9059: approx. 215 g

SL 9059: approx. 245 g

OA 9059: approx. 180 g

Dimensions

Width x height x depth:

IL 9059: 35 x 90 x 59 mm

SL 9059: 35 x 90 x 98 mm

OA 9059: 62 x 62 x 25 mm

Standard Type

IL 9059.11 3 AC 380 ... 690 V 40 ... 80 Hz

for mounting in consumer units or industrial distribution systems

Article number: 0062239

- Output: 1 changeover contact
- Nominal voltage U_N : 3 AC 380 ... 690 V
- Frequency range: 40 ... 80 Hz
- De-energized on trip
- Width: 35 mm

SL 9059.11 3 AC 380 ... 690 V 40 ... 80 Hz

for cabinets with mounting plate

Article number: 0065771

- Output: 1 changeover contact
- Nominal voltage U_N : 3 AC 380 ... 690 V
- Frequency range: 40 ... 80 Hz
- De-energized on trip
- Width: 35 mm

OA 9059.05/001 3 AC 380 ... 690 V 40 ... 80 Hz

for mounting in terminal box

Article number: 0065777

- Output: 1 NC contact
- Nominal voltage U_N : 3 AC 380 ... 690 V
- Frequency range: 40 ... 80 Hz
- Energized on trip
- Width: 62 mm

Dimension OA 9059

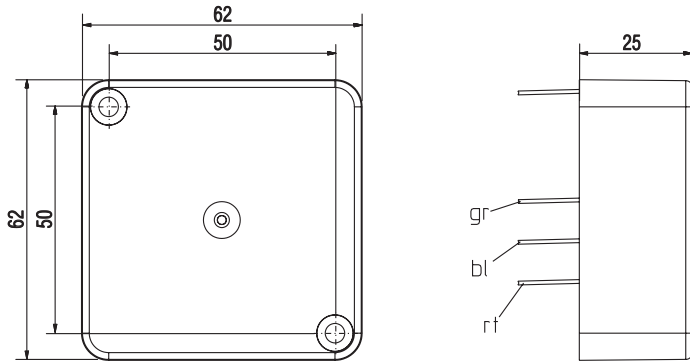

M10799

