

**MINISTART**  
Phase Controller  
IN 9017

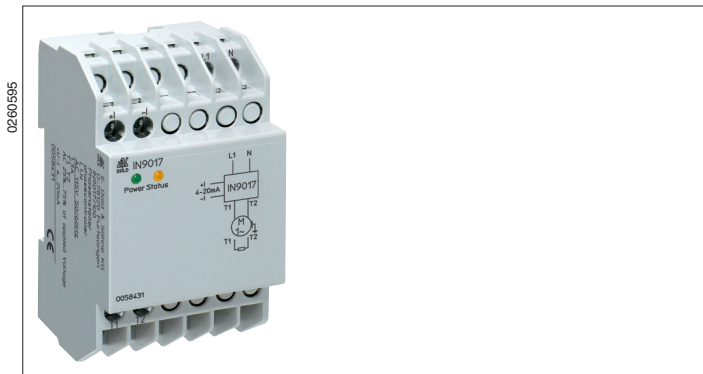

- Phase controller for resistive and motor load
- for permanent power up to 300 W
- Interference suppression limit value class B
- LED indication
- **Devices available in 3 versions:**
  - IN 9017/100:** with current interface 4 ... 20 mA and broken wire detection
  - IN 9017/200:** with voltage interface 0 ... 10 V
  - IN 9017/211:** with voltage interface 0 ... 10 V,  $U_{min}$  adjustable, control input for max. output current
- Width: 53 mm

**Block Diagrams**

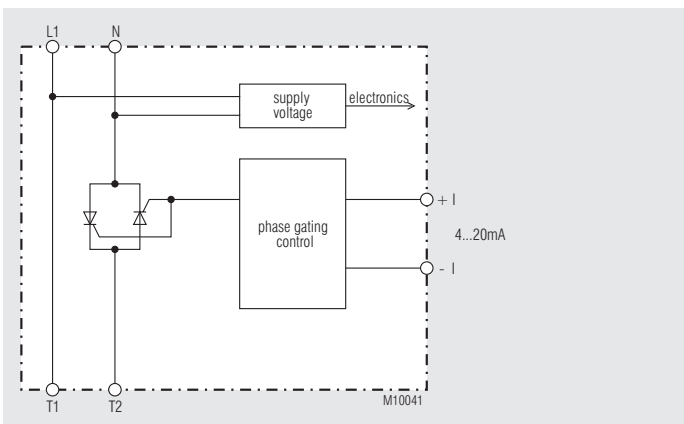

IN 9017/100

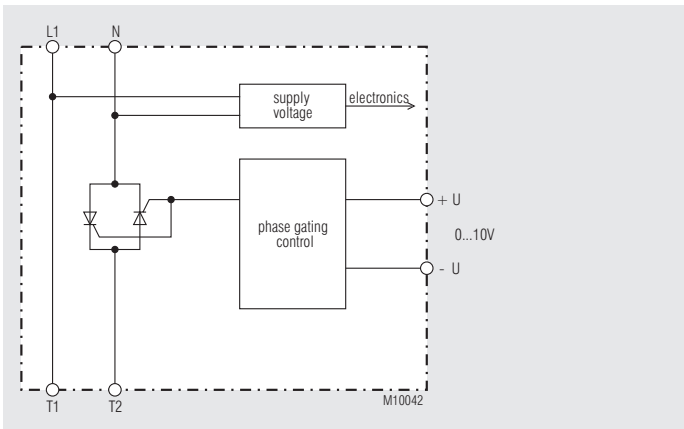

IN 9017/200

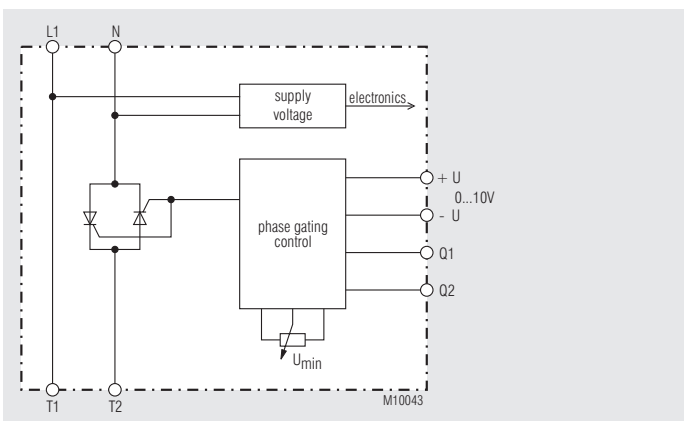

IN 9017/211

**Approval and Marking**



**Application**

- Resistive load
- Infrared heating
- Fan
- Volume compressor

**Function**

Phase controllers robust electronic units to control the voltage by phase chopping. The Phase chopping angle is adjusted on a control input. (IN 9017/100: 4 ... 20 mA, IN 9017/200: 0 ... 10 V) verstellt.

The variant IN 9017/211 is realised with 0...10V input and voltfree contact input Q1, Q2.

When contact input Q1, Q2 is open the output remains off at 0-3 V. With 3V control voltage the voltage adjusted on potentiometer  $U_{min}$  is switched on. When rising the control voltage continuously up to 10 V on the input, the output voltage increases up to AC 230 V. By closing the contact on Q1, Q2 the the output supplies the max. voltage.

**Indication**

- LED green: supply voltage is present  
 LED yellow
- at IN 9017/100: Permanent on, when control current > 4 mA  
 flashes 1 time, when control current < 4 mA (cable break)  
 flashes 2 times, when mains frequency is outside limits
- at IN 9017/200: Permanent on, when full voltage on motor is present  
 flashes 1 time, when phase gating is active  
 flashes 2 times, when mains frequency is outside limits
- at IN 9017/211: Permanent on, when full voltage on motor is present  
 flashes 1 time, when phase gating is active  
 flashes 2 times, when mains frequency is outside limits  
 flashes 3 times, when setpoint < 3 volt and Q<sub>1</sub>, Q<sub>2</sub> are open

## Notes

If the power semiconductor should be protected against short circuit or ground fault during operation a superfast fuse needs to be installed (see technical details). If not the standard line protection fuses must be used. The phase controller must not be operated with capacitive load on the output. To provide safety for people and equipment, only trained staff must work on this unit.

## Technical Data

### Motor voltage

IN 9017/100:	AC 48 V	±10 %
IN 9017/100:	AC 115 V	±10 %
IN 9017/100:	AC 230 V	±10 %
IN 9017/200:	AC 115 V	±10 %
IN 9017/200:	AC 230 V	±10 %
IN 9017/211:	AC 230 V	±10 %

### Nominal frequency:

50 / 60 Hz  
300 W at AC 230 V  
150 W at AC 115 V

### Min. power:

approx. 0.1 P<sub>N</sub>

### Rated current:

1.3 A

### Semiconductor fuse

(superfast): 20 A

### Setting range output voltage

IN 9017/100:	AC 48 V	AC 12 ... 36 V
IN 9017/100:	AC 115 V	AC 29 ... 86 V
IN 9017/100:	AC 230 V	AC 58 ... 172 V
IN 9017/200:	AC 115 V	AC 20 ... 115 V
IN 9017/200:	AC 230 V	AC 40 ... 230 V
IN 9017/211:	AC 230 V	AC U <sub>min</sub> ... 230 V

### Recovery time:

200 ms

### Consumption:

1.4 VA

### Control input

IN 9017/100:	4 ... 20 mA	R <sub>i</sub> = 82.5 Ω
IN 9017/200:	0 ... 10 V	R <sub>i</sub> = 50 kΩ
IN 9017/211:	0 ... 10 V	R <sub>i</sub> = 50 kΩ
	Q <sub>1</sub> , Q <sub>2</sub> ,	volt free

## General Data

**Nominal operating mode:** continuous operation

**Temperature range:** 0 ... + 55 °C

**Storage temperature:** - 25 ... + 75 °C

### Clearance and creepage distance

Rated impuls voltage /  
pollution degree: 4 kV / 3 IEC 60 664-1

### EMC

Electrostatic discharge: 8 kV (air) IEC/EN 61 000-4-2

HF irradiation: 10 V/m IEC/EN 61 000-4-3

Fast transients: 2 kV IEC/EN 61 000-4-4

Surge voltage

between

wires for power supply: 1 kV IEC/EN 61 000-4-5

between wire and ground: 2 kV IEC/EN 61 000-4-5

HF-wire guided: 10 V IEC/EN 61 000-4-6

Interference suppression: Limit value class B EN 55 011

### Degree of protection

Housing: IP 40 IEC/EN 60 529

Terminals: IP 20 IEC/EN 60 529

### Housing:

thermoplastic with VO behaviour

according to UL subject 94

### Vibration resistance:

Amplitude 0.35 mm

frequency 10 ... 55 Hz, IEC/EN 60 068-2-6

### Climate resistance:

0 / 055 / 04 IEC/EN 60 068-1

### Terminal designation:

EN 50 005

### Wire connection:

2 x 2.5 mm<sup>2</sup> solid or

2 x 1.5 mm<sup>2</sup> stranded wire with sleeve

DIN 46 228-1/-2/-3/-4

### Wire fixing:

Flat terminals with self-lifting clamping

piece IEC/EN 60 999-1

### Mounting:

DIN-rail

IEC/EN 60 715

### Weight:

210 g

## Dimensions

**Width x height x depth:** 53 x 90 x 61 mm

## Standard Types

IN 9017/100 AC 48 V 75 W  
Article number:: 0062206

IN 9017/100 AC 115 V 150 W  
Article number:: 0058431

IN 9017/100 AC 230 V 300 W  
Article number:: 0065838

IN 9017/200 AC 115 V 150 W  
Article number:: 0065592

IN 9017/200 AC 230 V 300 W  
Article number:: 0058274

IN 9017/211 AC 230 V 300 W  
Article number:: 0059425

## Set-up Procedure

1. Wiring of the component according to connection example
2. Adjust required output voltage

## Safety remarks

- Never clear fault when the device is switched on
- The user must ensure that the device and the necessary components are mounted and connected according to the locally applicable regulations and technical standards.
- After disconnection of the device dangerous voltages may be sensed for several minutes on the connection terminals caused by filter capacitors.

## Attention:

This device can be started by potential-free contact, while connected directly to the mains without contactor. Please note, that the load is not physically separated from the mains. Because of this the load must be disconnected from the mains via the corresponding manual motor starter.



## Control Characteristics

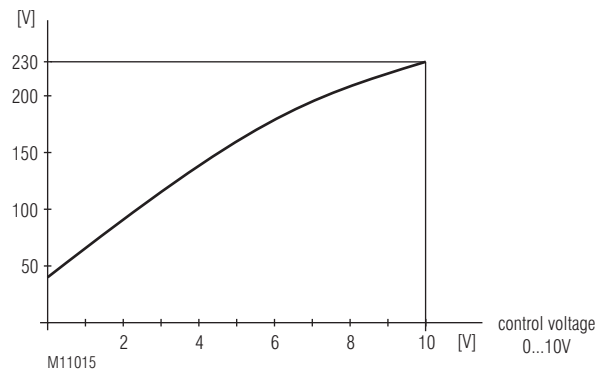

## IN 9017/200 AC 230 V

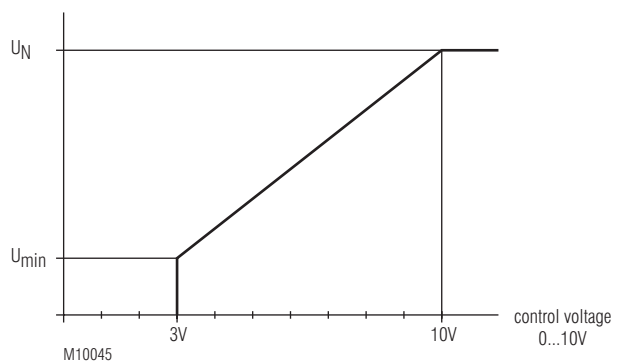

## IN 9017/211

## Application Examples

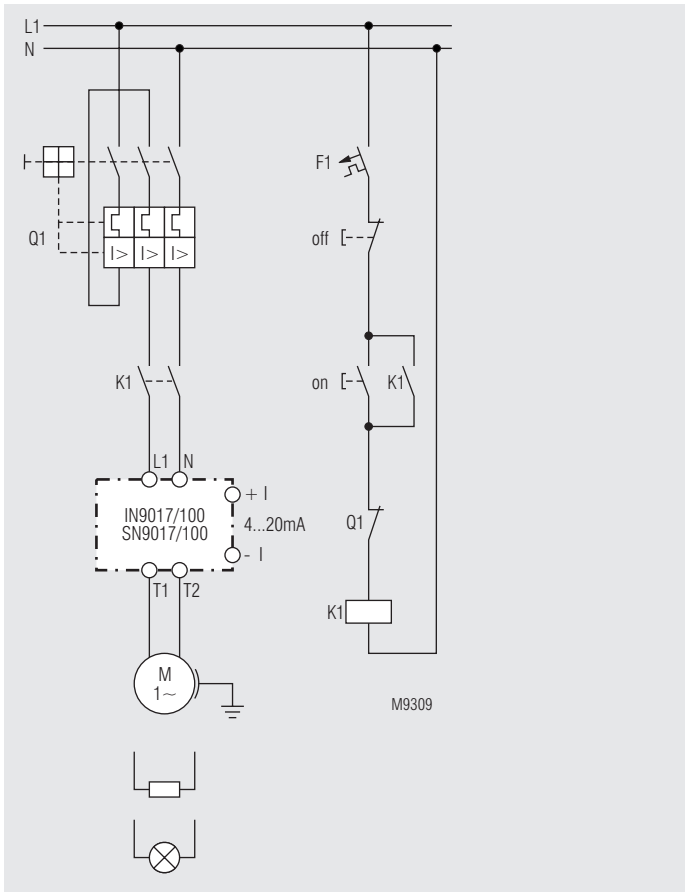

IN 9017/100

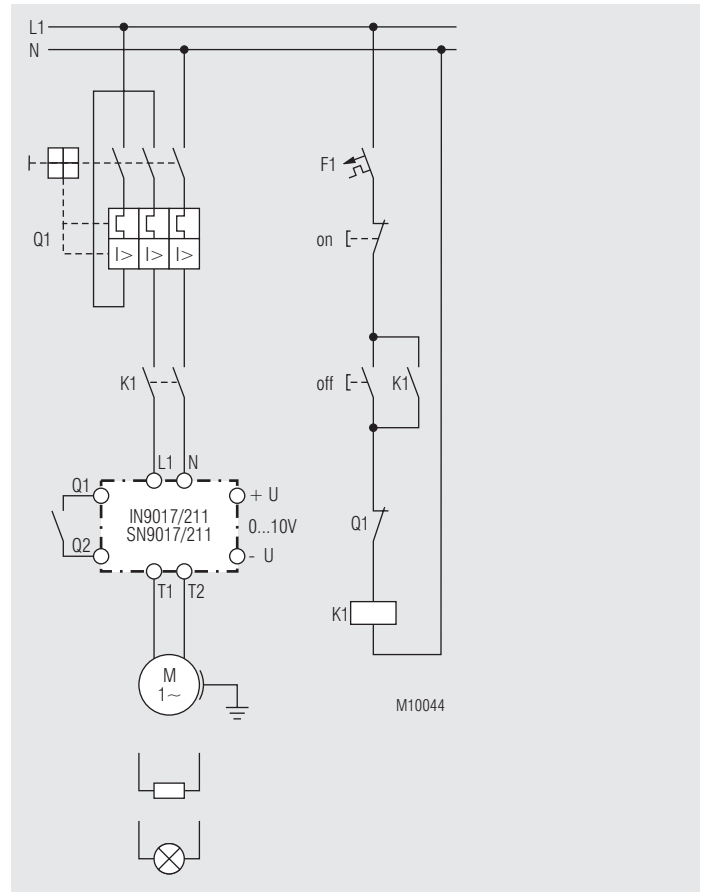

IN 9017/211

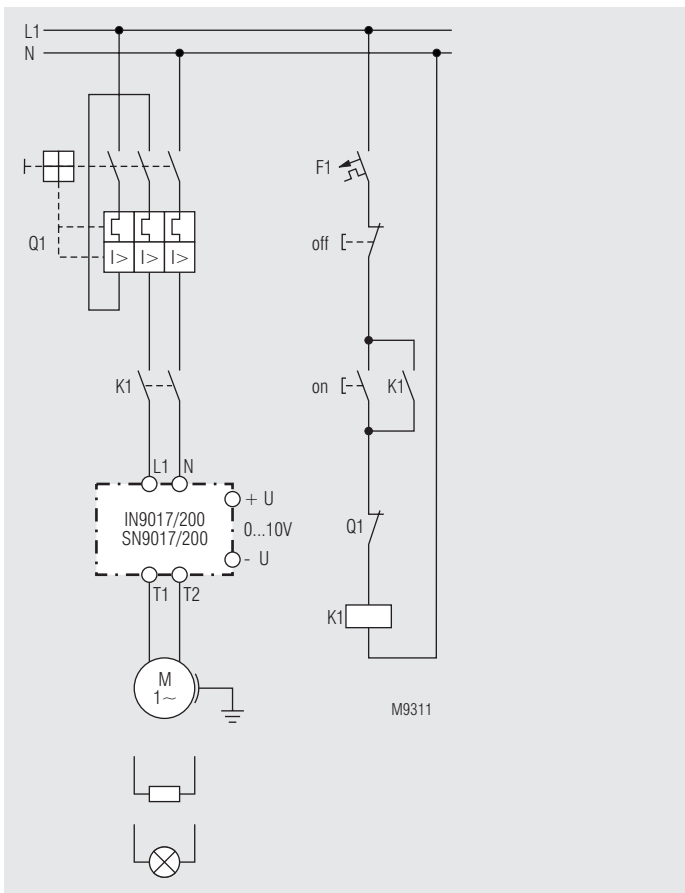

IN 9017/200

