

MINISTOP Motor Brake Relay BI 9034



02/60271

Your advantages

- Higher safety level and more economic by short stopping cycle
- Cost saving
- Compact design
- Easy to set-up, no need for current measuring instrument

Features

- According to IEC/EN 60947-4-2
- For all single and 3-phase asynchronous motors
- DC-brake with one way rectification up to max. 60 A
- Controlled by microcontroller
- Easily fitted to existing installations
- Wear free and maintenance free
- Integrated braking contactor
- DIN-rail mounting
- Adjustable braking current up to max. 60 A (controlled current)
- With integrated star-delta starting function
- With automatic standstill detection
- Variant /800 with short circuit contactor control for reduced brake delay time
- 90 mm Width

Block Diagrams

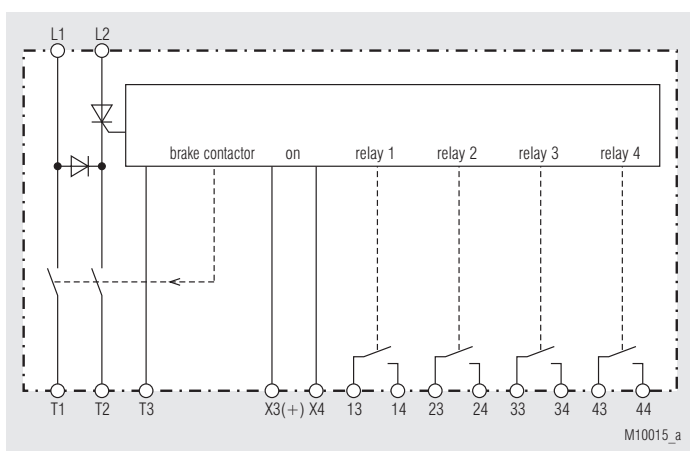

BI 9034

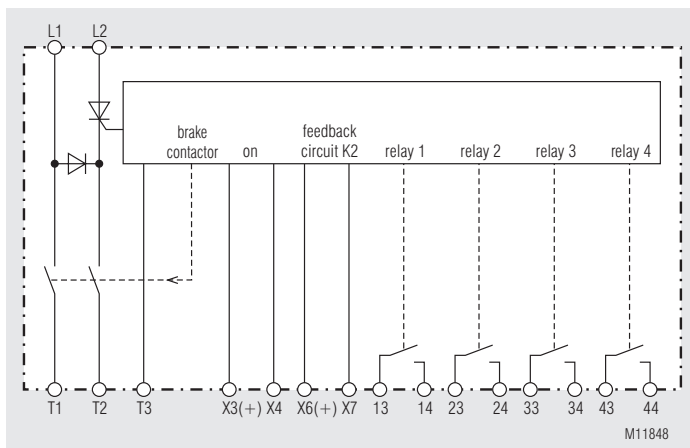

BI 9034/800

Approvals and Markings



Applications

- Saws
- Centrifuges
- Woodworking machines
- Textile machines
- Conveyors

Function

The supply voltage is connected to terminals L1-L2 and the interlock contact X5-X6 closes to enable the motor contactor. A green LED indicates operation. The motor can be started with an ON push button. Depending on the position of the rotary selector switch the motor starts direct on line or with star-delta start. The braking DC-voltage is generated on terminals T₁ and T₂. The braking sequence is as follows:
Pressing the stop button de-energises the motor contactor. The closing of X3-X4 (contact of the motor contactor) starts the braking. After a safety time the braking contactor closes for the adjusted braking time and the braking current flows through the motor.
To reduce the brake delay time there is a variant /800 with a short circuit contactor control. By using a contactor controlled by relay 2, the motor windings are shortcircuited on motor stop. This cuts down the back emf very fast. The braking of the motor can be started faster. The braking cycle is time controlled, no standstill detection.

Notes

Terminal 3 is the measuring input for standstill detection. The BI 9034 can be also used without connecting T3. Standstill will be detected by the current measuring. It is important to make sure, that the braking current will flow longer than 2 s before stopping the motor. If the motor stops too early, the standstill will not be detected and the braking current will flow for the maximum braking time.

To have an optimum standstill detection make sure that the braking current is higher than the nominal current of the motor.

If the back-EMF of the motor drops only slowly the unit may have a braking delay of up to 2 s.

The variant /800 allows to reduce the brake delay time down to 250 ms.

Function Diagrams

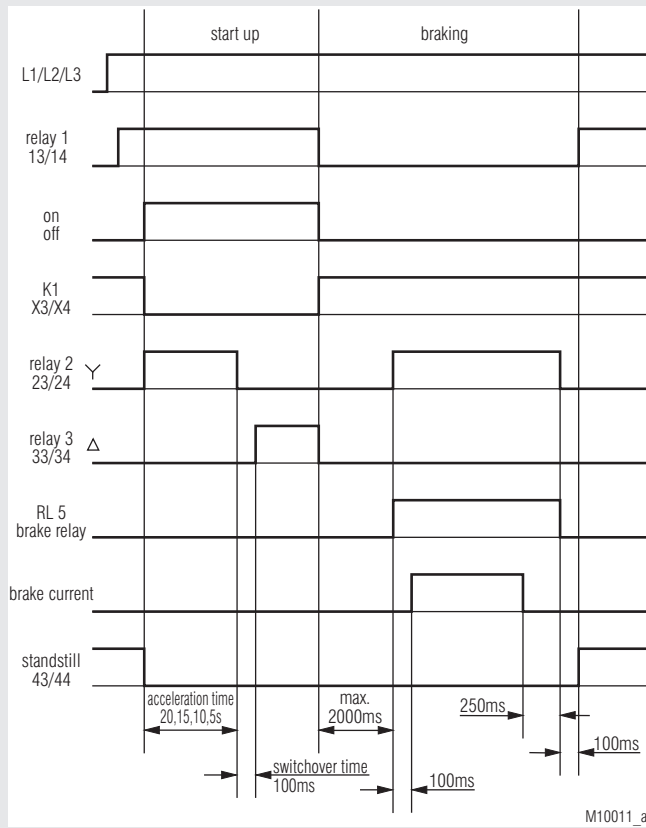

BI 9034 Function 1 ... 4

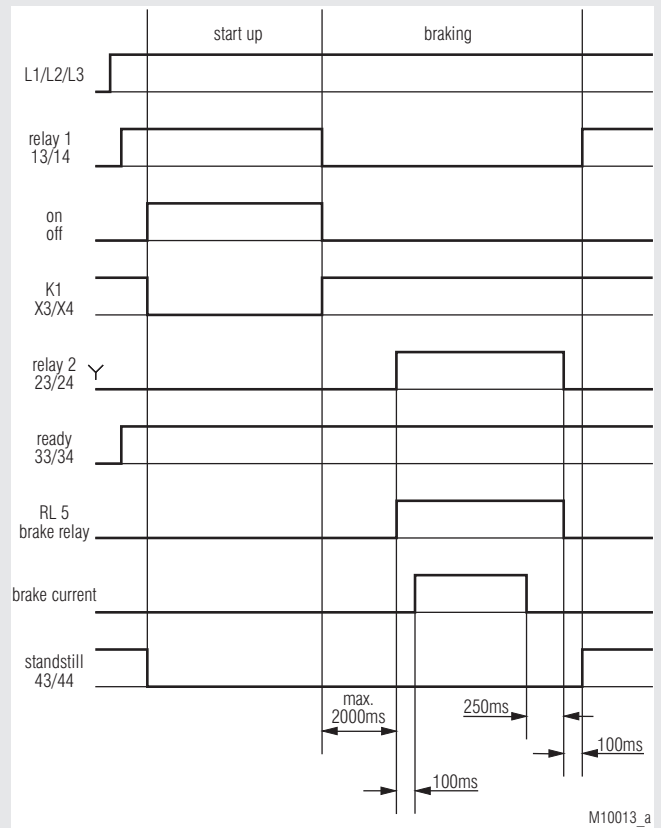

BI 9034 Function 5

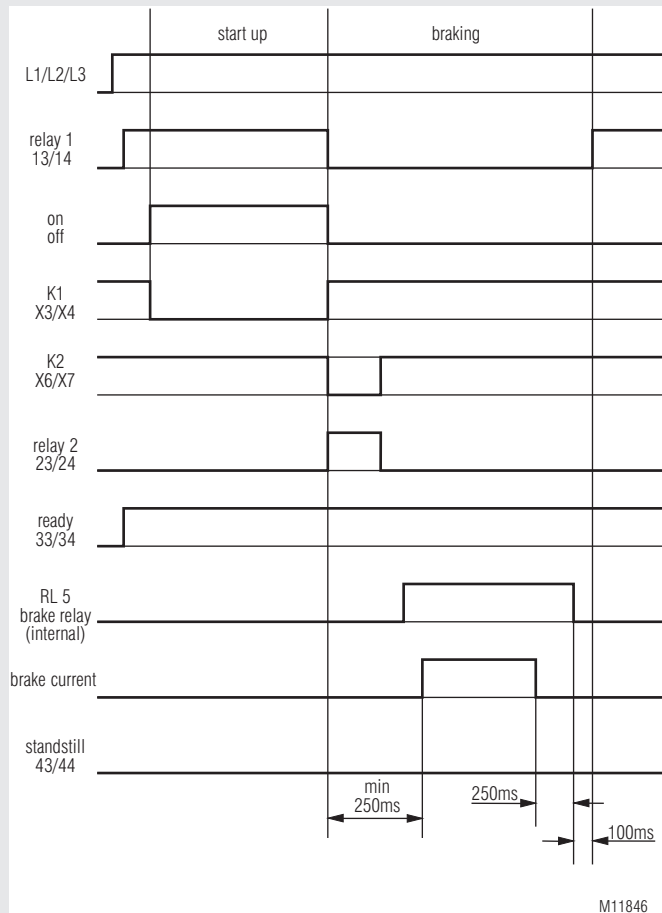

BI 9034/800

Circuit Diagrams

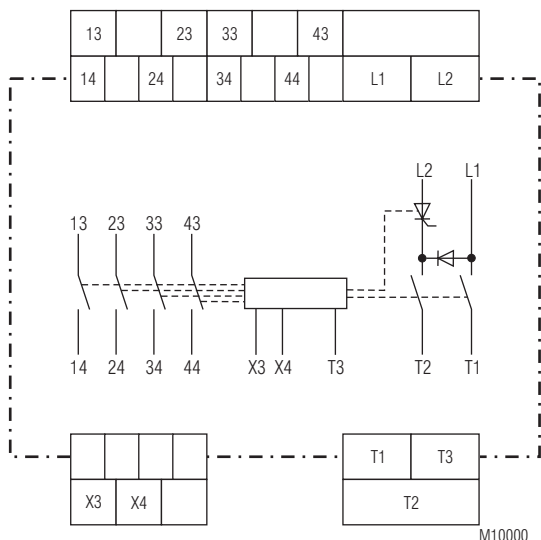

BI 9034

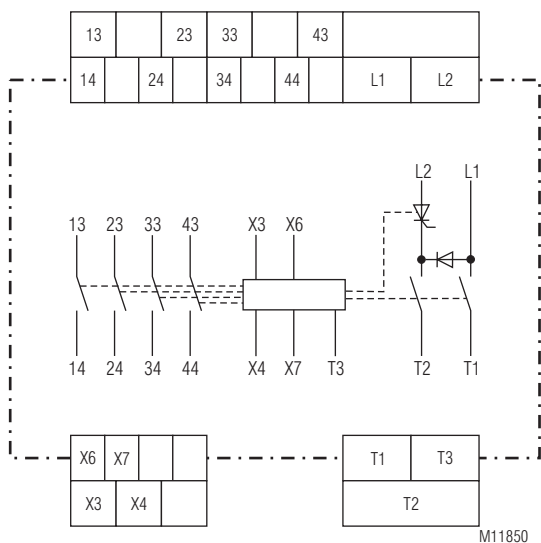

BI 9034/800

Connection Terminals

Terminal designation	Signal designation
L1	Phase voltage L1
L2	Phase voltage L2
T1	Motor connection T1
T2	Motor connection T2
T3	Motor connection T3 (stand still detection)
X3	(+) Feed back motor contactor
X4	Feed back motor contactor
13, 14	Monitoring relay 1
23, 24	Monitoring relay 2
33, 34	Monitoring relay 3
43, 44	Monitoring relay 4
X6	(+) Feed back short circuit contactor (/800 only)
X7	Feed back short circuit contactor (/800 only)

Indicators

LED green „RUN“:	- ready:	permanent on
LED red „Error“	- Mains frequency out of tolerance	1 flash
	- Braking current is not present:	2 flashes
	- Power semiconductors overheated:	flashes 3 times
	- Synchronisation signal is not present:	flashes 4 times
	- Temperature measuring circuit defective:	flashes 5 times
	- Motor voltage not disconnected:	flashes 6 times
	- Variant /800 only short circuit contactor not de-energized:	flashes 7 times
LED yellow „I _{Br} “	- max. braking time 11 s	permanent on
	- Braking current is present	permanent on
	- max. braking time 31 s	flashes
	- Braking current is present	flashes

Technical Data

Nominal Voltage U_N:	AC 230 V ± 10 %, AC 400 V ± 10 %
Nominal frequency:	50/60 Hz ± 3 Hz
Permissible braking current:	10 ... 60 A _{eff}
Duty-cycle at max. braking current:	40 %
I²t-value of power semiconductors:	6600 A ² s
Braking voltage:	DC 10 ... 190 V
Braking delay for fade out of back EMF:	
BI 9034:	auto optimising (0.2 ... 2 s)
BI 9034/800:	0.25 s via short circuit contactor
Nominal consumption for control circuit:	5 VA
Fuses	
according to rule 1:	Type gL / 60 A
according to rule 2:	Type gR / I ² t 6600 A ² s

Output

Contacts:	4 NO contacts	2 A / AC 400 V
Switching capacity to AC 15		
NO contact:	3 A / AC 250 V	IEC/EN 60 947-5-1
Electrical life:	10 ⁵ switch. cycles	IEC/EN 60 947-5-1
Mechanical life:	10 ⁶ switch. cycles	IEC/EN 60 947-5-1
Permissible switching frequency:	1800 switching cycles / h	
Short circuit strength		
max. fuse rating:	4 A gG / gL	IEC/EN 60 947-5-1

General Data

Operating mode:	Continuous operation	
Temperature range		
Operation:	0 ... + 45 °C	
Storage:	- 25 °C ... + 75 °C	
Altitude:	< 1.000 m	
Clearance and creepage distance		
rated impulse voltage / pollution degree		
Nominal voltage-heat sink:	6 kV / 2	EN 50 178
Relay contacts to supply voltage:	4 kV / 2	IEC 60 664-1
Overvoltage:	III	
EMC		
Störfestigkeit		
Electrostatic discharge (ESD):	8 kV (air)	IEC/EN 61 000-4-2
HF irradiation:		
80 MHz ... 1.0 GHz:	10 V / m	IEC/EN 61 000-4-3
1.0 GHz ... 2.5 GHz:	3 V / m	IEC/EN 61 000-4-3
2.5 GHz ... 2.7 GHz:	1 V / m	IEC/EN 61 000-4-3
Fast transients:	2 kV	IEC/EN 61 000-4-4

Technical Data

Surge between wires for power supply:	1 kV	IEC/EN 61 000-4-5
between wire and ground:	2 kV	IEC/EN 61 000-4-5
HF-wire guided:	10 V	IEC/EN 61 000-4-6
Voltage dips		IEC/EN 61 000-4-11

Interference emission

Wire guided:	Limit value class A*)	IEC/EN 60 947-4-2
Radio irradiation:	Limit value class A*)	IEC/EN 60 947-4-2

*) The device is designed for the usage under industrial conditions (Class A, EN 55011). When connected to a low voltage public system (Class B, EN 55011) radio interference can be generated. To avoid this, appropriate measures have to be taken.

Degree of protection

Housing:	IP 40	IEC/EN 60 529
Terminals:	IP 20	IEC/EN 60 529

Housing: Thermoplastic with V0 behaviour according to UL subject 94

Vibration resistance:

Amplitude 0.35 mm,
Frequency 10 ... 55 Hz, IEC/EN 60 068-2-6
25 / 075 / 04 IEC/EN 60 068-1
EN 50 005

Climate resistance:

Terminal designation:

Wire connection

Load terminals:
1 x 10 mm² solid
1 x 6 mm² stranded ferruled
A current of 60 A or 80 A is permitted at a.m. duty cycles for 6 mm² wiring

Control terminals:
1 x 4 mm² solid or
1 x 2.5 stranded ferruled (isolated) or
2 x 1.5 mm² stranded ferruled (isolated)
DIN 46 228-1/-2/-3/-4 or
2 x 2.5 mm² stranded ferruled
DIN 46 228-1/-2/-3

Wire fixing

Load terminals: Plus-minus terminal screws M 4 box terminals with self-lifting clamping piece

Fixing torque: 1.2 Nm
Control terminals: Plus-minus terminal screws M 3,5 box terminals with self-lifting clamping piece

Fixing torque: 0.8 Nm

Mounting: DIN rail IEC/EN 60 715

Rail standard: EN 50 022

Weight: 780 g

Dimensions

Width x height x depth: 90 x 85 x 120 mm

Standard Type

BI 9034 60 A AC 400 V 50 / 60 Hz 2 ... 11 s

Article number: 0062127

- Integrated braking contactor
- DIN-rail mounting
- Width: 90 mm

Ordering Example

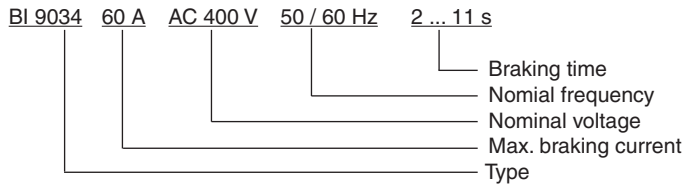

Variants on Request

- Second control input e.g. to interrupt braking cycle
- 2 galvanic separated DC 24 V inputs e.g. for control via PLC
- Braking time 1 ... 31 s or to customers specification
- Relay function to customers specification
- Special voltages on request
- Device with time controlled braking cycle, without stand still monitoring, without star-delta-control on request

Control Input

By opening a contact (motor contactor switches on) on terminals X3 (+24V) and X4 (signal) star-delta starting begins when function 1...4 is selected. After the adjusted time delay the delta contactor comes on and the brake units waits for the closing of the contact on X3-X4 (stop button is pressed). After closing of this contact the braking cycle starts.

The variant /800 has an extra input X6 (+24V) and X7 (signal) to give feed back from the short circuit contactor K2. The braking cycle is only started when the feed back circuit after operation of the short circuit contactor is closed again.

Monitoring Output

13, 14:	Interlock contact for motor contactor.
23, 24:	Control of star contactor of a star delta starter during start and braking.
33, 34	a) Control of delta contactor when function 1...4 is selected b) ready signal when function 5 is selected
43, 44	Standstill signal, resets on motor start or in case of a failure.

Variante /800

13, 14:	Interlocking for motor contactor
23, 24:	Control of short circuit contactor
33, 44:	Ready signal
43, 44:	No function

On device failure all contacts open

Adjustment Facilities

BI 9034:

Potentiometer	Description	Grundeinstellung
I_{Br}	Braking current	Fully anti-clockwise
Fkt	Function	Fully anti-clockwise

BI 9034/800:

Potentiometer	Benennung	Grundeinstellung
t_{Br}	Braking time	Fully clockwise

The braking current is controlled according to the adjusted value in Ampere.

For optimum braking the setting of the current should be max. 1.8 to 2 times the motor current. This corresponds to the saturation current of the magnetic field used to brake the motor. A higher current only overheats the motor. A higher braking efficiency can be obtained by using 2 or more stator windings. The permitted duty cycle is depending on the actual braking current and the ambient temperature.

The different functions of the brake unit can be selected with rotary switch Fkt

Fkt 1 ... 4:

- Star-Delta-control with internal timing
- Relay 1 - Motor contactor
- Relay 2 - Star-contactor
- Relay 3 - Triangle contactor
- Relay 4 - Stand still

Acceleration time (star-contactor):

- Fkt 1 - 20 s
- Fkt 2 - 15 s
- Fkt 3 - 10 s
- Fkt 4 - 5 s

Fkt 5:

- Star-Delta-control with external timing
- Relay 1 - Motor contactor
- Relay 2 - Star-contactor
- Relay 3 - Ready
- Relay 4 - Stand still

Set-up Procedure

- Connect the motor brake relay BI 9034 in accordance to the connection example and make sure to connect the same phases between (L1, L2) and /T1, T2). Make sure that the interlocking contact 13, 14 is wired in series to the coil of the motor contactor so that the motor contactor cannot switch on, while the braking current is flowing
- Select function with rotary switch Fkt
- Set the braking current on potentiometer I_{Br} (braking time at variant /800). To avoid overloading of the motor set the current to max. two times the nominal motor current
- The braking time of the BI 9034 (except for BI 9034/800) cannot be adjusted. Due to the standstill detection it is self-optimizing. If L3 is not connected to T3, standstill detection is provided by measuring the braking current.
- If no standstill is detected, the BI 9034 stops braking after 10 s e.g. 30 s

Fault Indication by Flashing Code

During normal operation failure messages may occur. The messages are indicated by a flashing sequence of the „Error“ LED

Flashes	Fault	Reason	Failure recovery
1 x	Mains frequency out of tolerance	Wrong mains frequency	Device not suitable for the frequency. Contact manufacturer
2 x	Braking current is not present	Braking current circuit broken Motor coil resistance is too high	Check the wiring Set braking current lower until the error disappears
3 x	Power semiconductors overheated	Permitted duty cycle exceeded	Decrease current and set the braking time longer. Wait till heat sink cools down
4 x	Synchronisation signal is not present	Unit defective or temporary interruption of power supply	The unit has to be repaired Switch unit Off and On
5 x	Temperature measuring circuit defective	Unit defective or overtemperature on power semiconductors while switching on	The unit has to be repaired Wait till heat sink cools down
6 x	Motor is still connected to voltage while braking should start already	Motor contactor welded Wiring incorrect	Change motor contactor Check wiring
7 x	Short circuit contactor not de-energised when braking cycle should be started	Short circuit contactor welded, faulty wiring	Exchange short circuit contactor, check wiring

Connection Examples

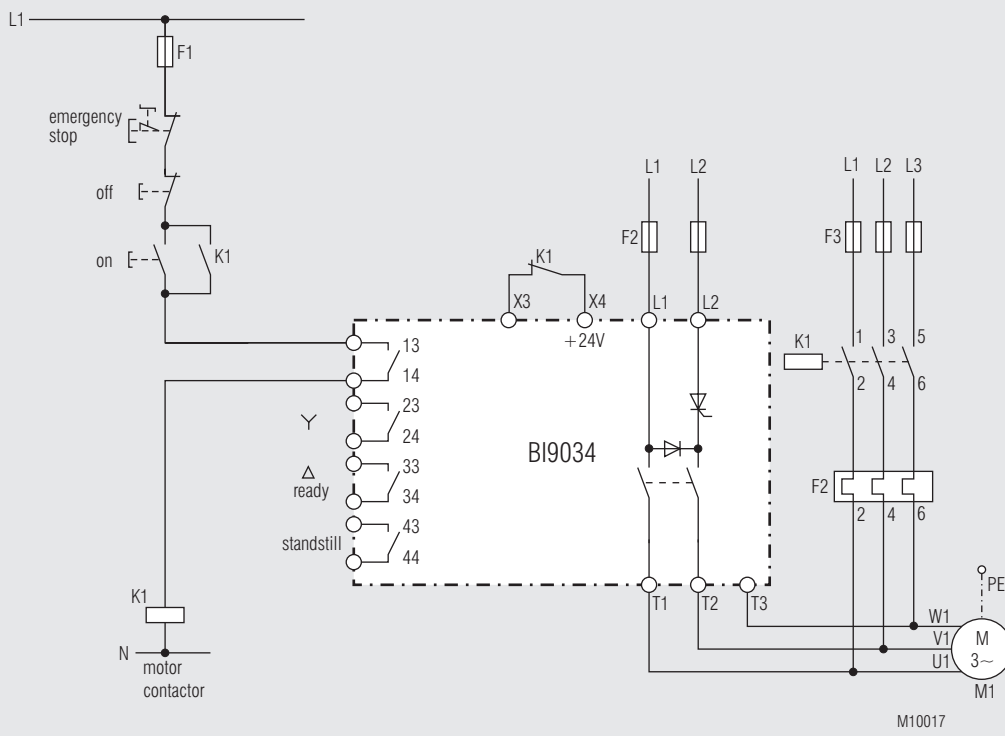

BI 9034 without star-delta-control

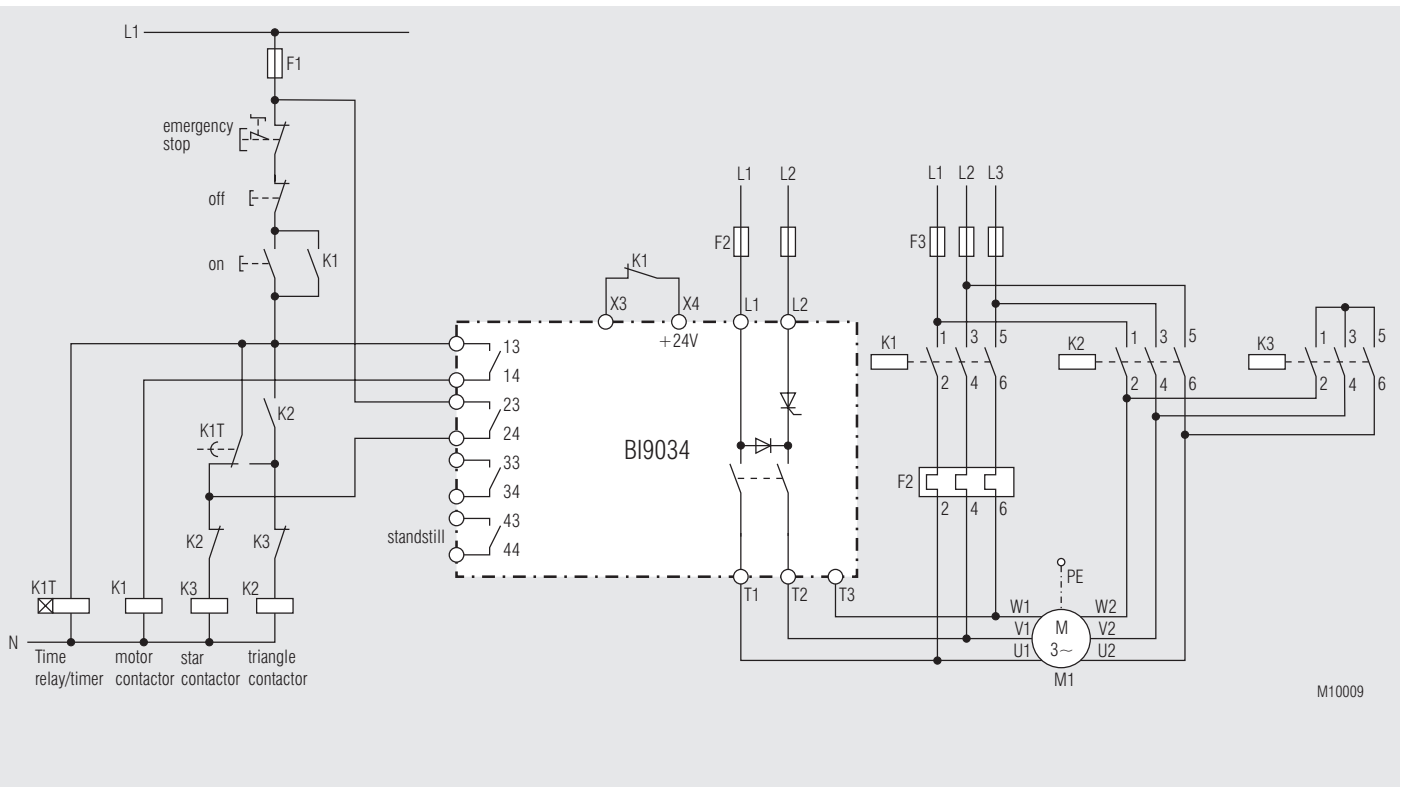

BI 9034 with external star-delta-control

Connection Example

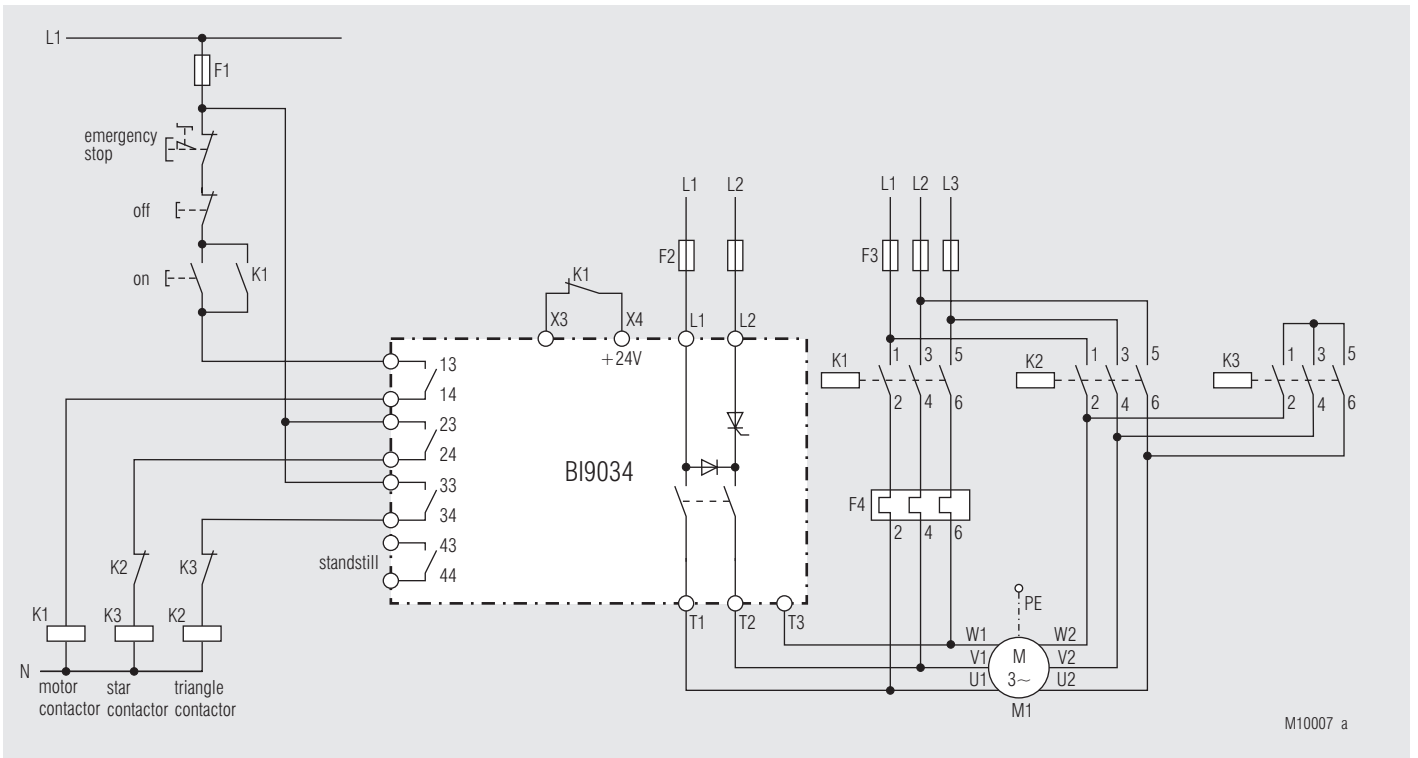

BI 9034 with internal star-delta-control

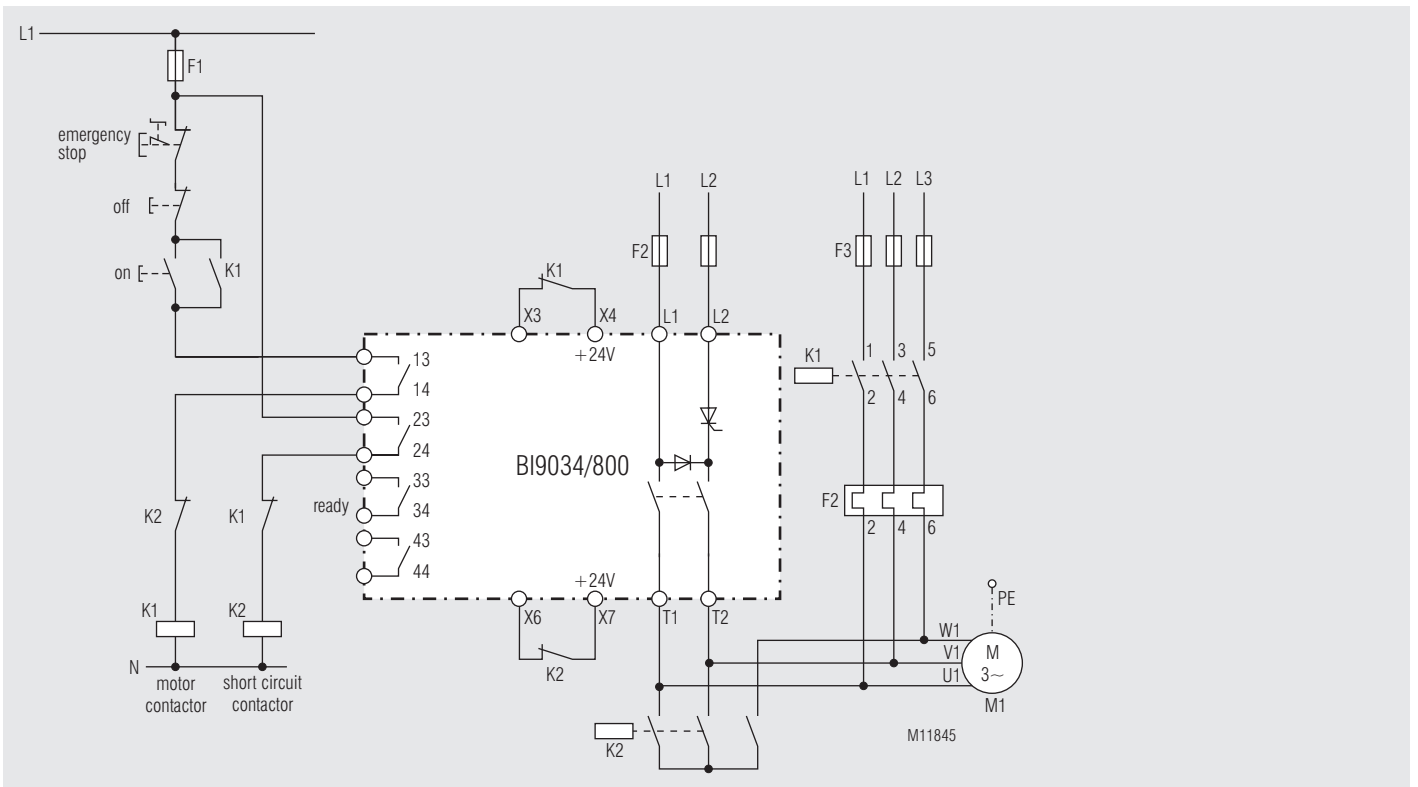

BI 9034/800 with reduced brake delay time

